

[CATÁLOGO]

VÁLVULAS FREELUB



SÉRIE 7000 - 1/4" - FREELUB

CARACTERÍSTICAS TÉCNICAS

Pressão	Máxima de 10,5 kgf/cm ² (150 psi)
Temperatura	-10°C a 80°C
Fluído	Ar comprimido filtrado
Vazão	1,64 m ³ /min (obtida a 7 kgf/cm ²)
Vias/posições	5 vias / 2 posições



MATERIAIS

Corpo	Alumínio injetado
Carretel	Zamak injetado
Êmbolo	Alumínio com Anodização Dura
Vedações	Poliuretano - PU

As válvulas da linha Freelub oferecem a possibilidade de trabalho sem lubrificação devido a tecnologia das vedações. Importante observar que, uma vez que entrarem em contato com óleo, a característica da vedação é alterada e a lubrificação se torna necessária.

CODIFICAÇÃO

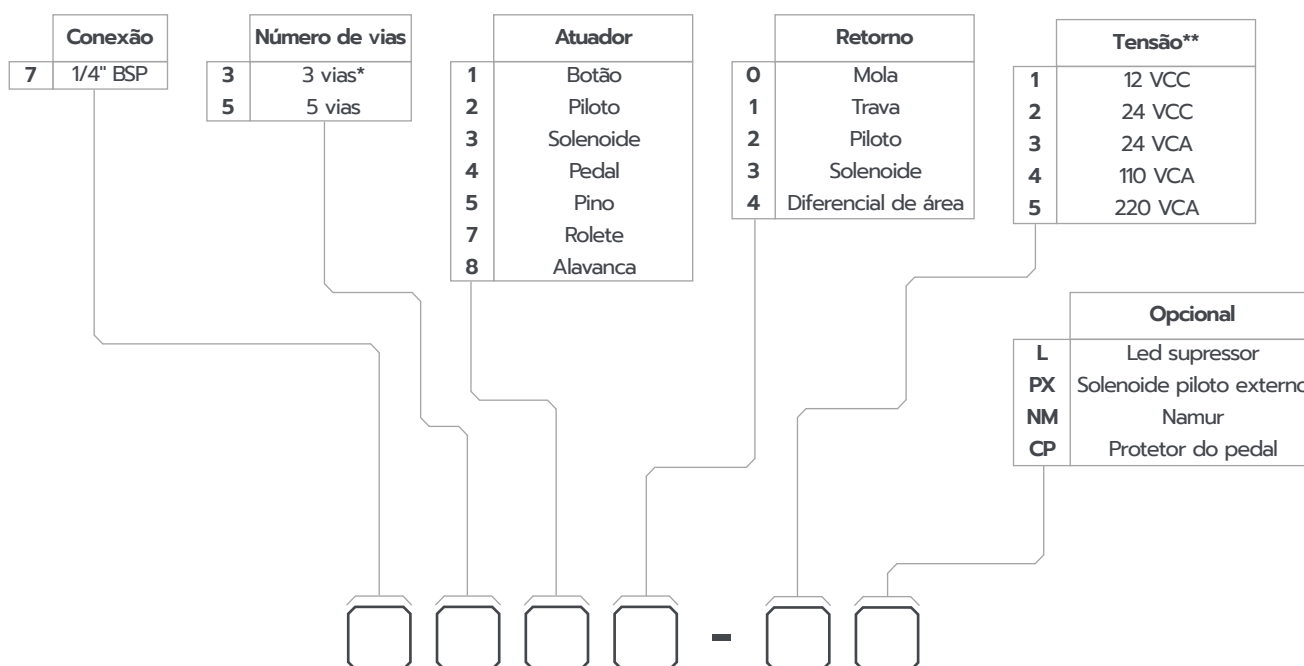

* Válvula de três vias, para linha Freelub, é fornecida no mesmo corpo 5 vias porém com 2 tampões.

** Utilizar referência de tensão somente quando atuador for solenóide.

KIT DE REPARO

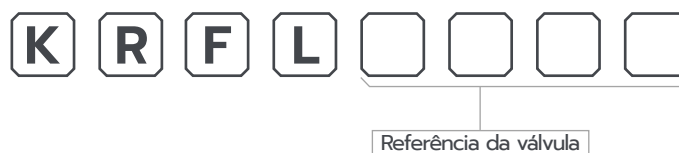

DIMENSIONAL

Botão Trava/Mola 5 e 3 vias

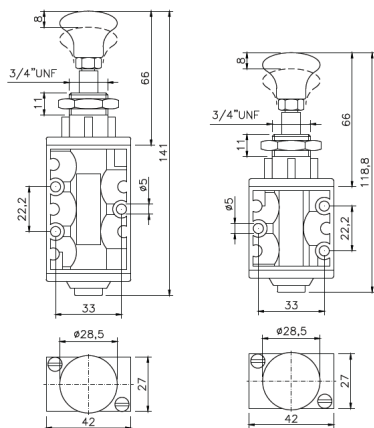

Botão Piloto 5 e 3 vias

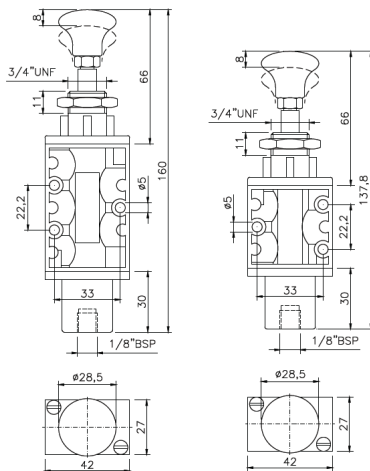

Pino Mola 5 e 3 vias

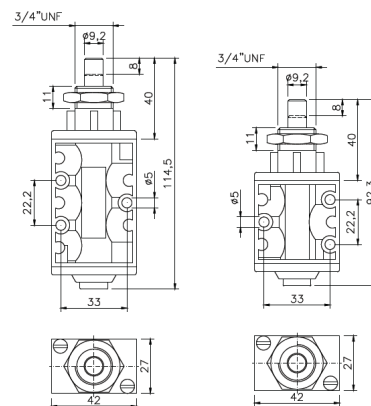

Pino Piloto 5 e 3 vias

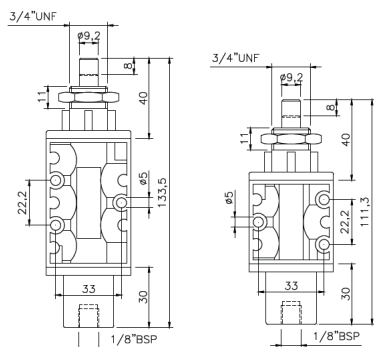

Duplo Piloto 5 e 3 vias

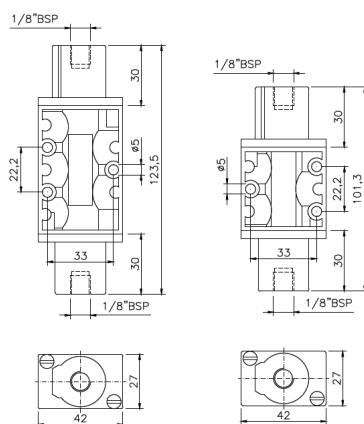

Piloto Mola 5 e 3 vias

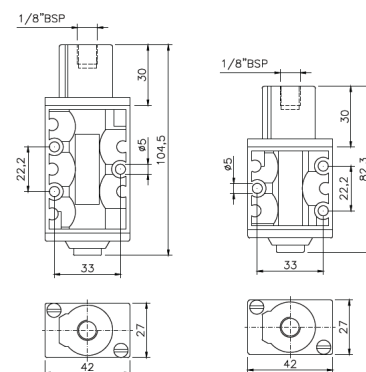

Rolete Mola 5 e 3 vias

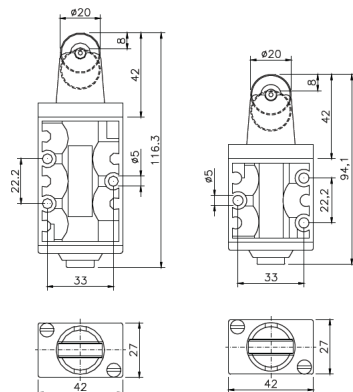

Alavanca Trava/Mola 5 vias

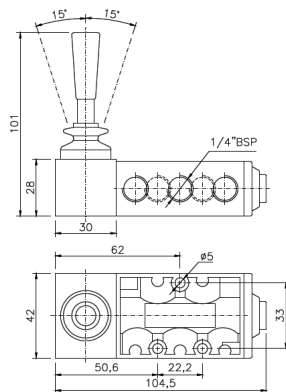

Alavanca Trava/ Mola 3 vias

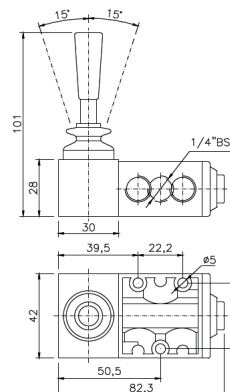

Solenóide Mola 5 vias

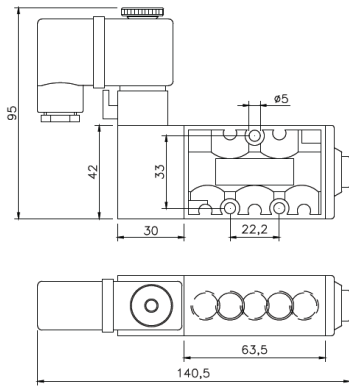

Solenóide Mola 3 vias

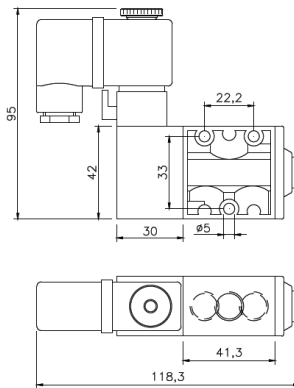

Solenóide Piloto 5 vias

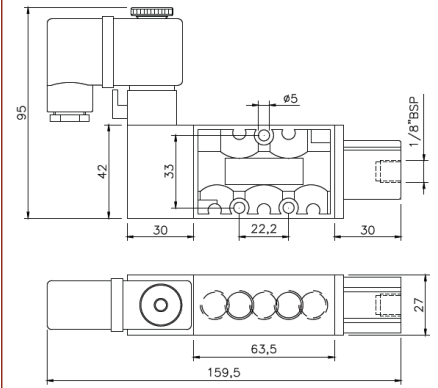

Solenóide Piloto 3 vias

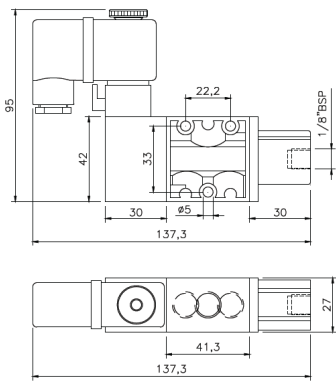

Duplo Solenóide 5 vias

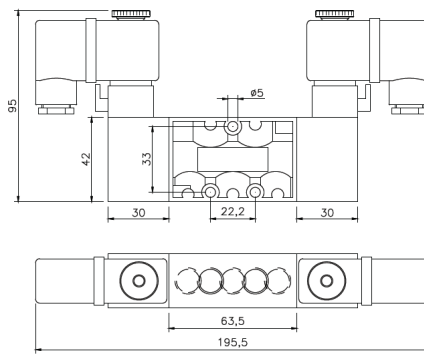

Duplo Solenóide 3 vias

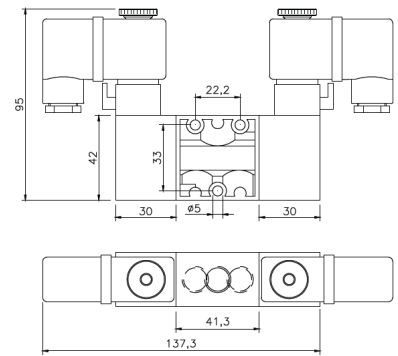

Solenóide Diferencial 5 vias

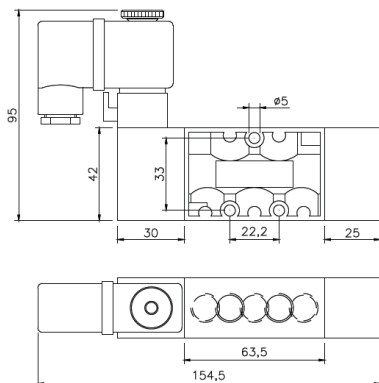

Solenóide Diferencial 3 vias

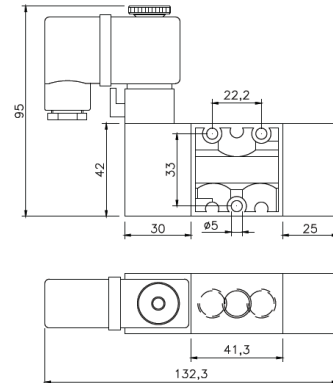

Pedal Mola 5 vias

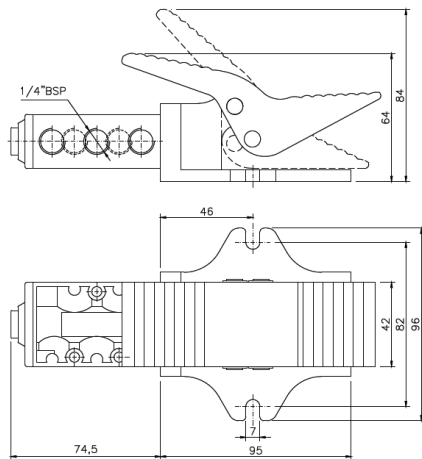

Pedal Mola 3 vias

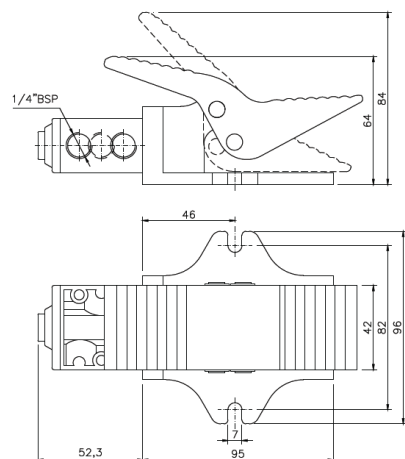

Pedal Piloto 5 vias

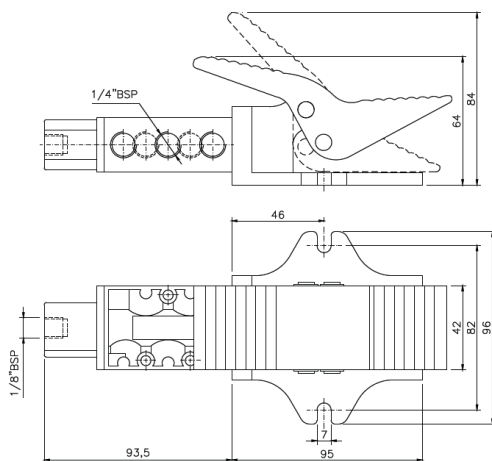

Pedal Piloto 3 vias

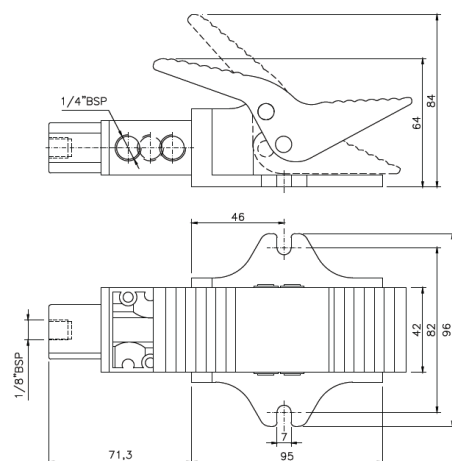

Pedal Diferencial 5 vias

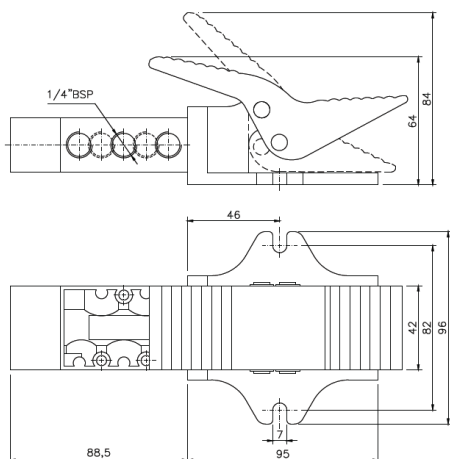

Pedal Diferencial 3 vias

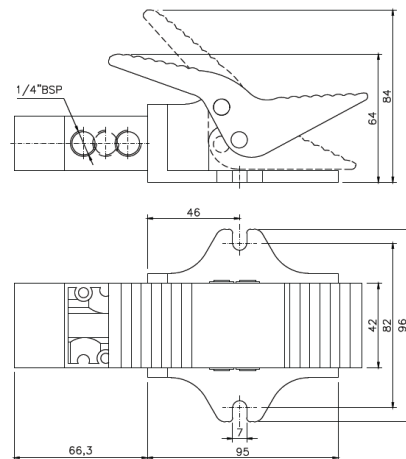

Botão Mola 5 Vias - 3 posições

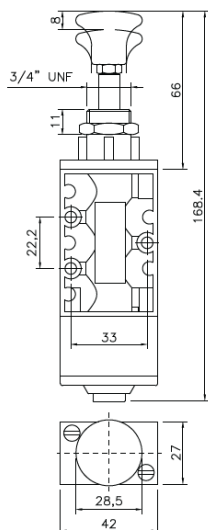

Botão Mola 3 Vias - 3 posições

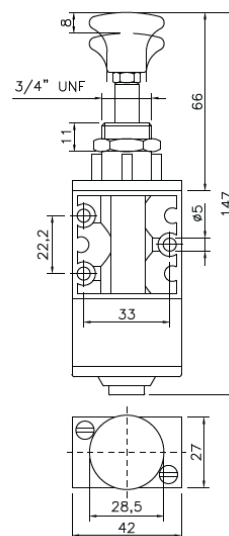

Duplo Piloto 5 Vias - 3 posições

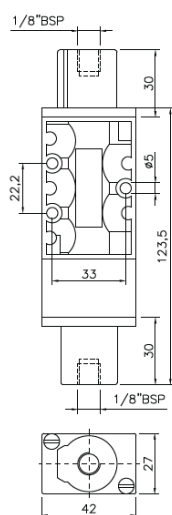

Duplo Piloto 3 Vias - 3 posições

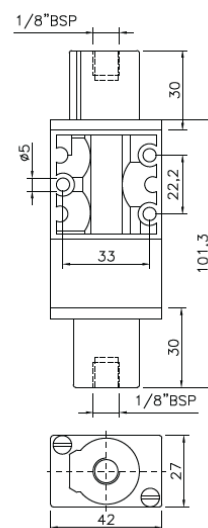

Duplo Solenoide 5 Vias - 3 posições

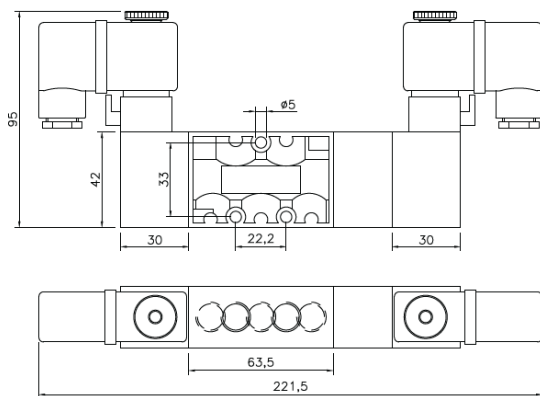

Duplo Solenoide 3 Vias - 3 posições

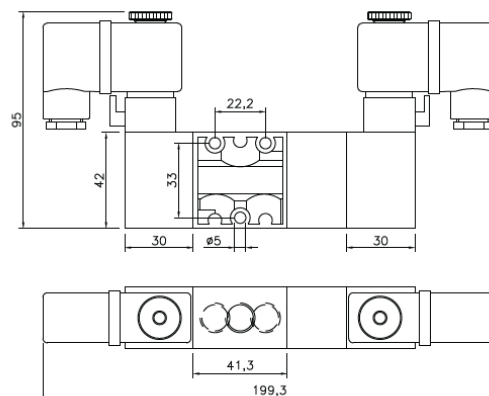

Pedal Mola 5 Vias - 3 posições

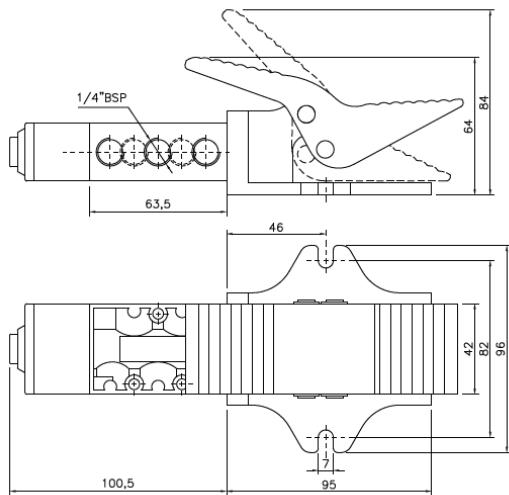

Pedal Mola 3 Vias - 3 posições

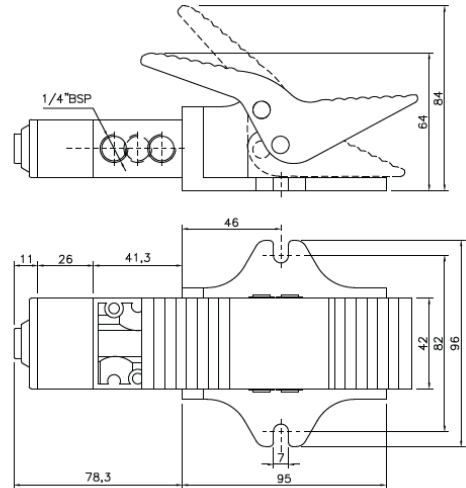

Alavanca Mola 5 Vias - 3 posições

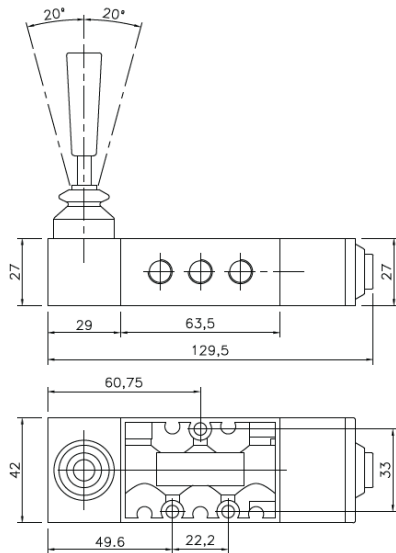

Alavanca Mola 3 Vias - 3 posições

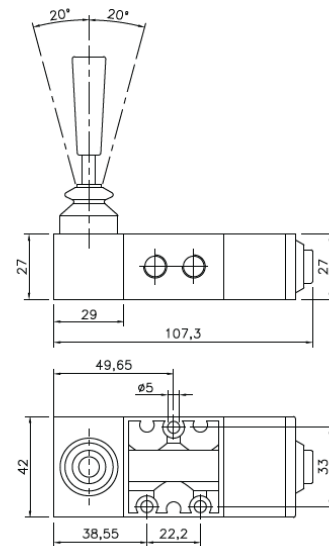

Alavanca Trava 5 Vias - 3 posições

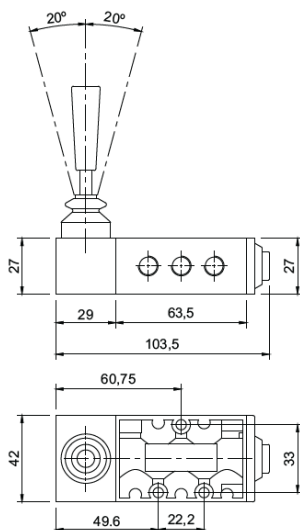

Alavanca Trava 3 Vias - 3 posições

