

{CATÁLOGO}

VÁLVULAS SÉRIE 4.000



VÁLVULAS DIRECIONAIS - SÉRIE 4000 - 3/4"

CARACTERÍSTICAS TÉCNICAS

Pressão	Máxima de 10,5 kgf/cm ² (150 psi)
Temperatura	-10°C a 80°C
Fluído	Ar comprimido filtrado e lubrificado
Vazão	4,7 m ³ /min (obtida a 7 kgf/cm ²)
Construção	Tipo <i>Spool</i>



MATERIAIS

Corpo	Alumínio
Carretel	Zamak
Êmbolo	Alumínio com Anodização Dura
Vedações	Buna-N



CODIFICAÇÃO

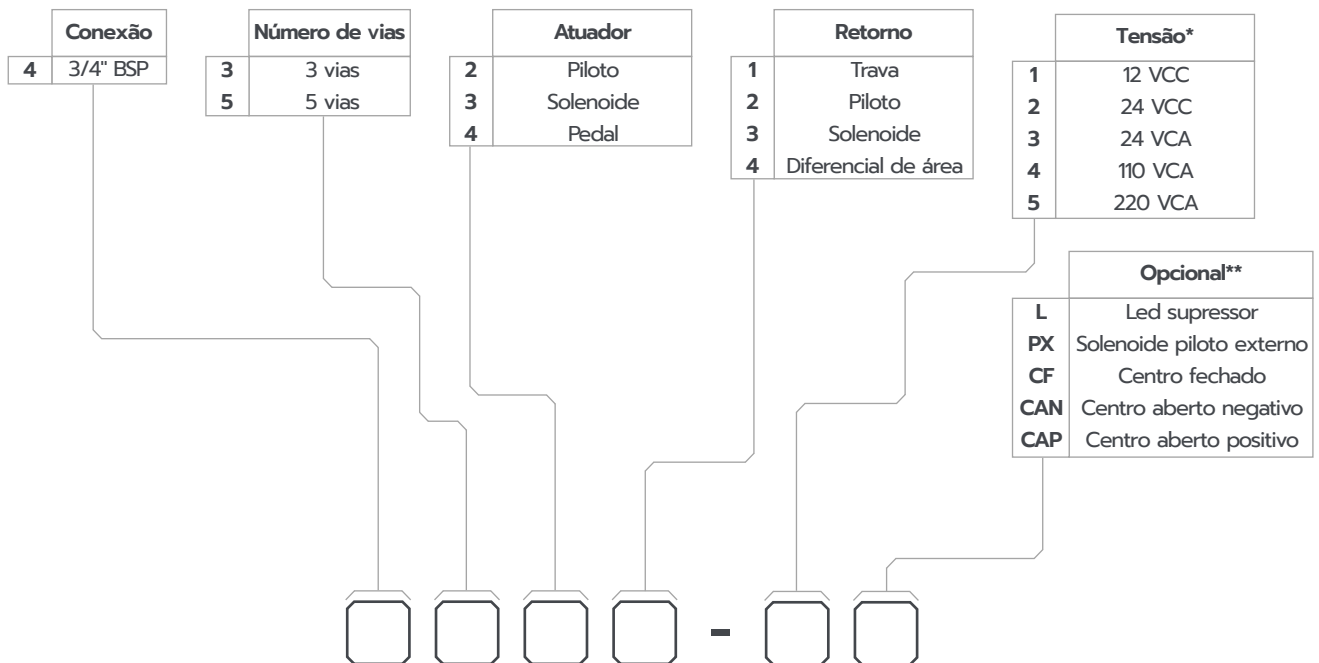

* Utilizar referência de tensão somente quando atuador for solenóide.

** As válvulas centro fechado (CF), centro aberto negativo (CAN) e centro aberto positivo (CAP) são 3 posições.

KIT DE REPARO

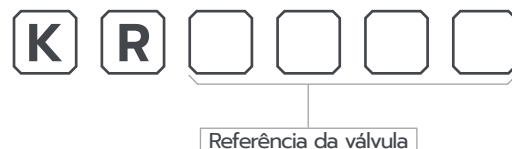

DIMENSIONAL

Duplo Piloto 3 Vias

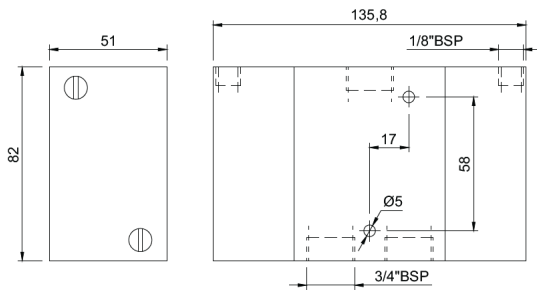

Duplo Piloto 5 Vias

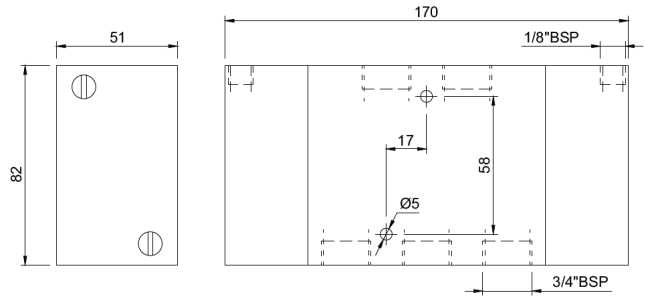

Solenóide Piloto 3 Vias

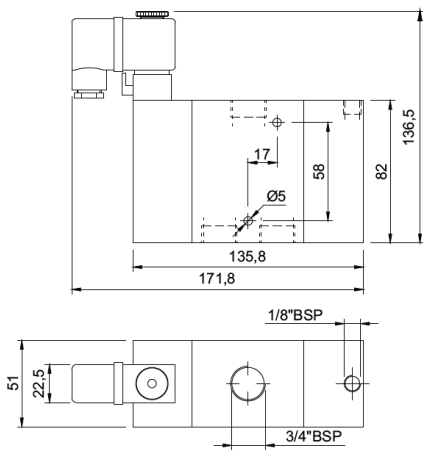

Solenóide Piloto 5 Vias

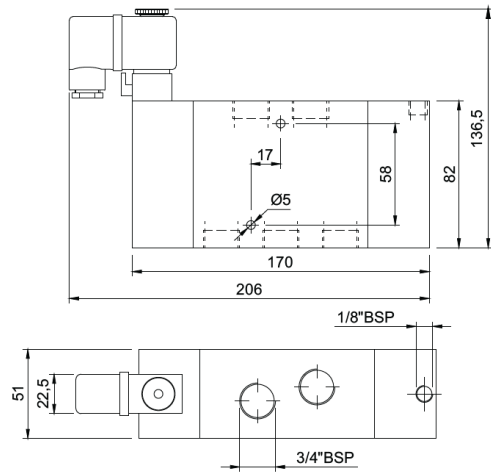

Piloto Diferencial 3 Vias

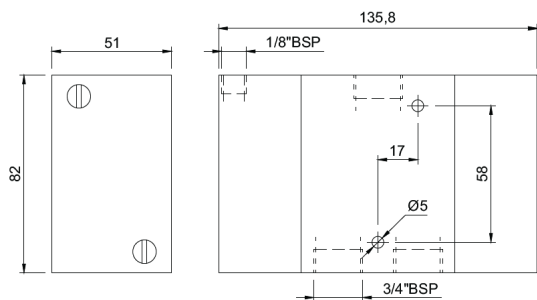

Piloto Diferencial 5 Vias

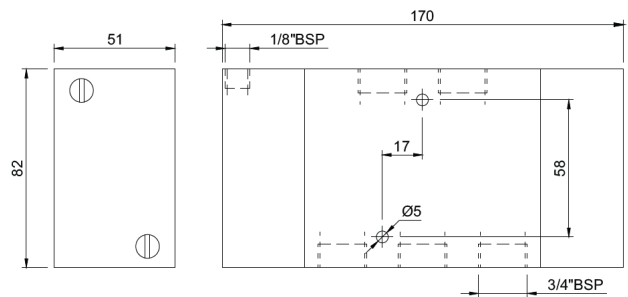

Duplo Solenoide 3 Vias

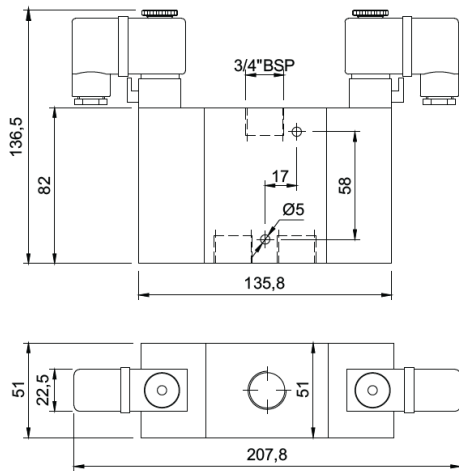

Duplo Solenoide 5 Vias

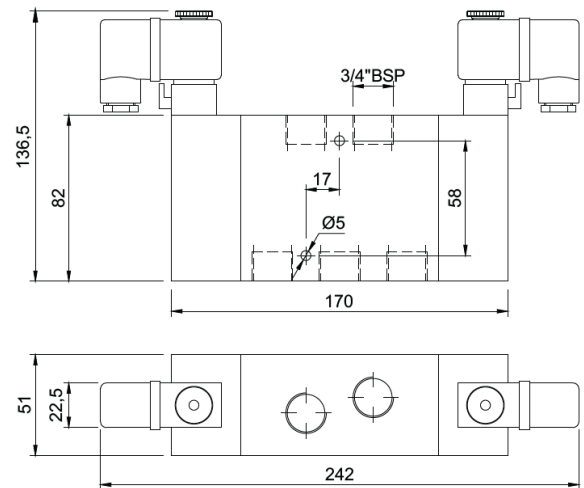

Solenoide Diferencial 3 Vias

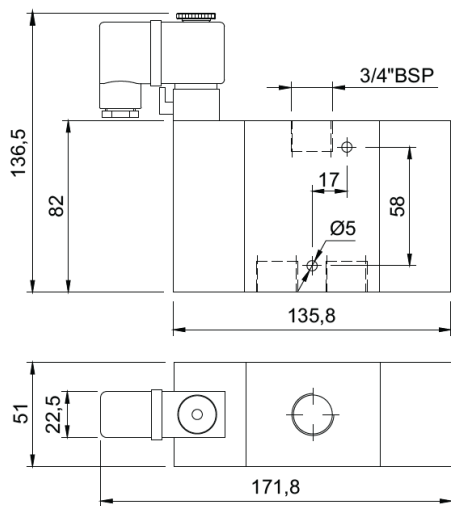

Solenoide Diferencial 5 Vias

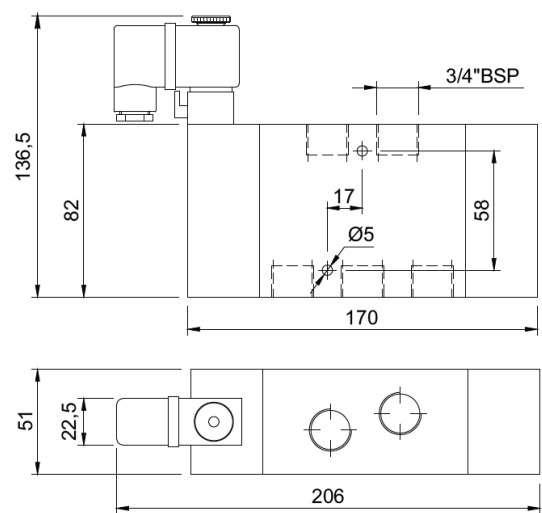

Pedal Trava 3 Vias

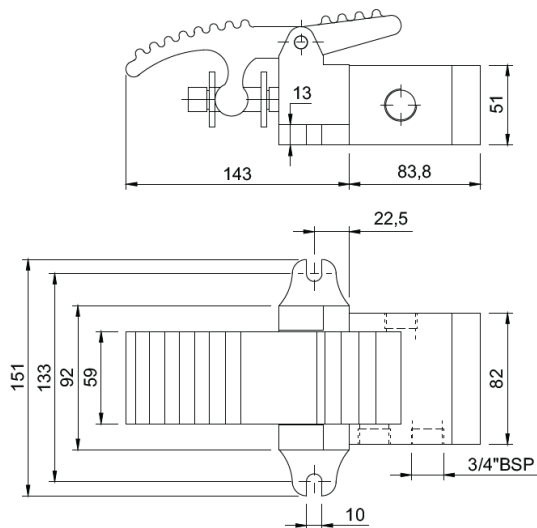

Pedal Trava 5 Vias

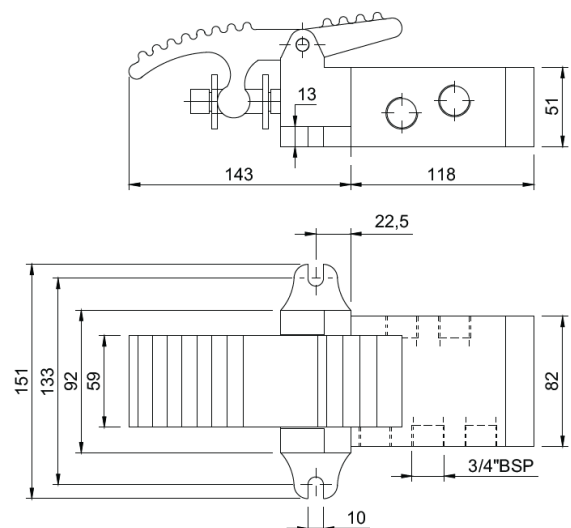

Pedal Diferencial 3 Vias

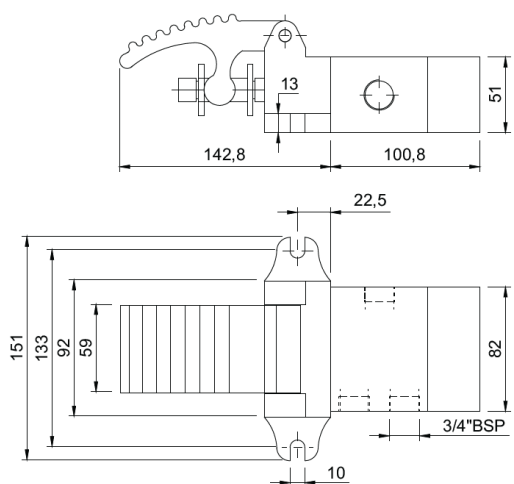

Pedal Diferencial 5 Vias

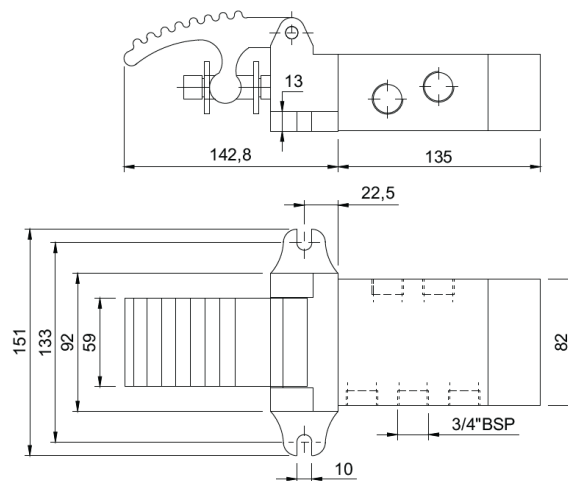

Duplo Piloto 3 Vias - 3 posições

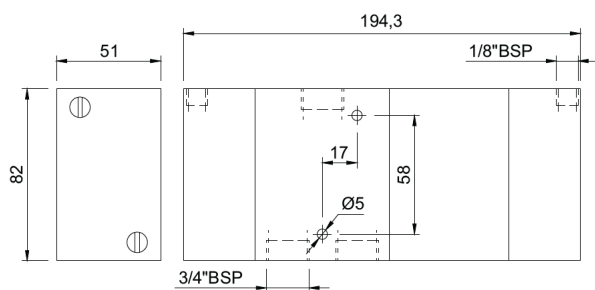

Duplo Piloto 5 Vias - 3 posições

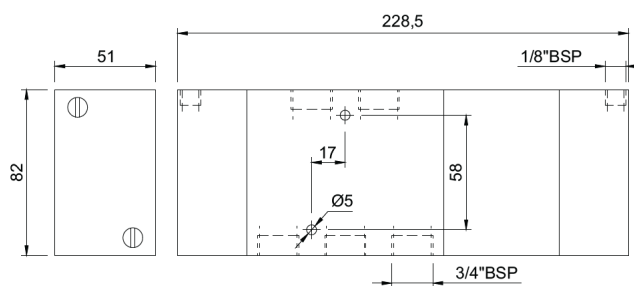

Solenóide Piloto 3 Vias - 3 posições

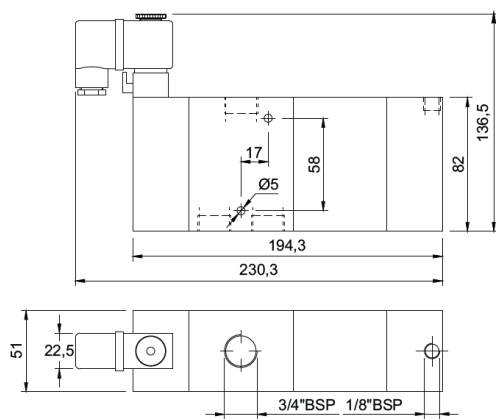

Solenóide Piloto 5 Vias - 3 posições

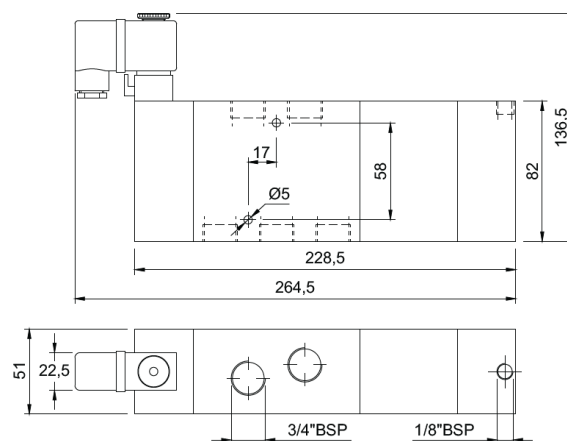

Duplo Solenoide 3 Vias

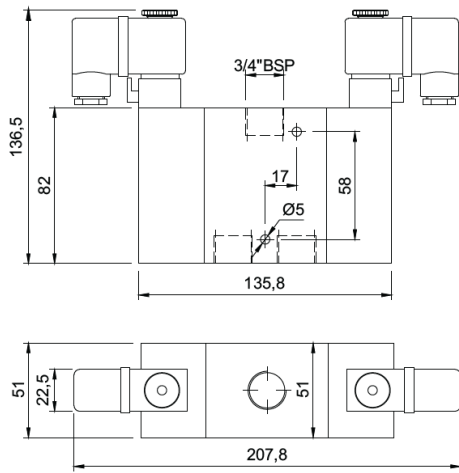

Duplo Solenoide 5 Vias

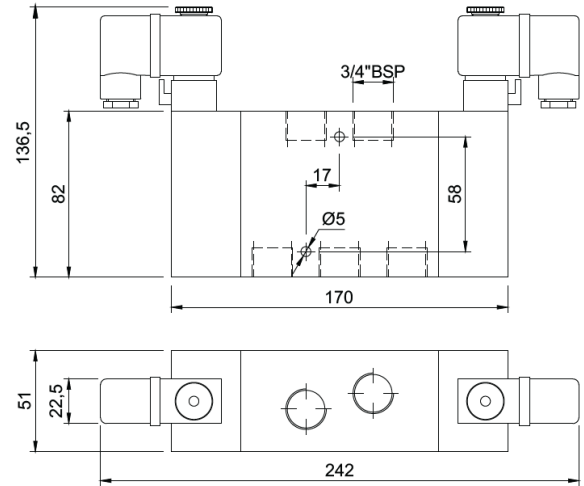

Solenoide Diferencial 3 Vias

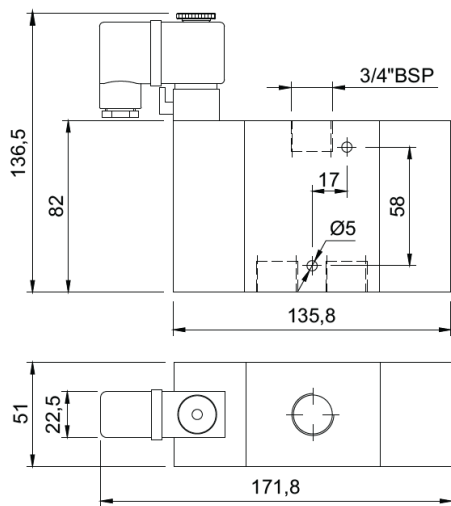

Solenoide Diferencial 5 Vias

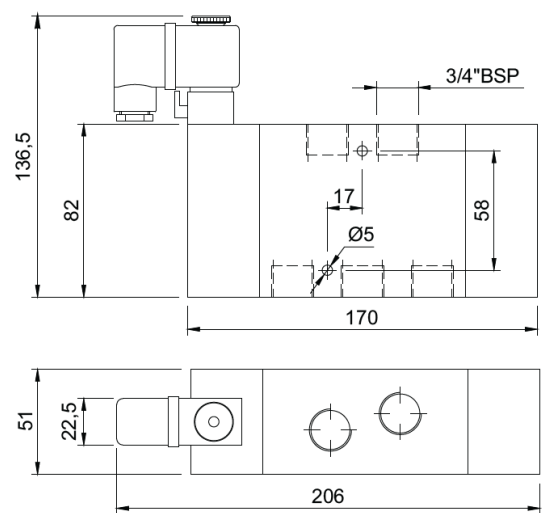

Pedal Trava 3 Vias

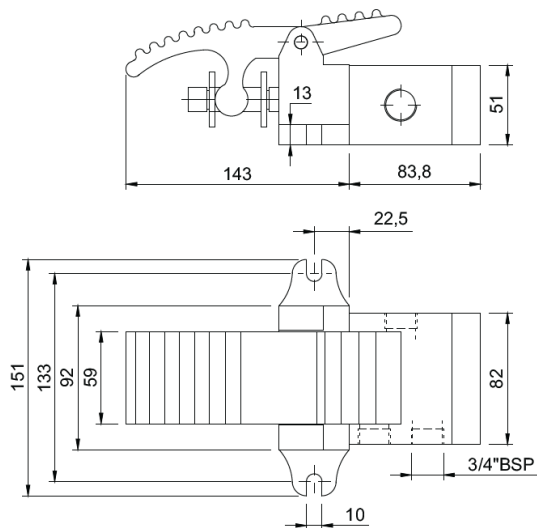

Pedal Trava 5 Vias

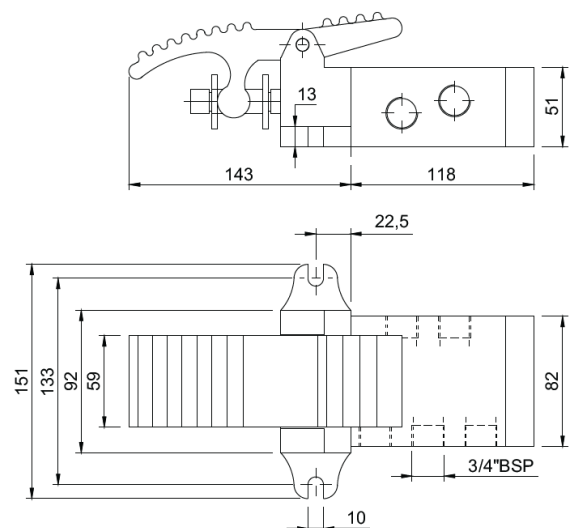

Pedal Diferencial 3 Vias

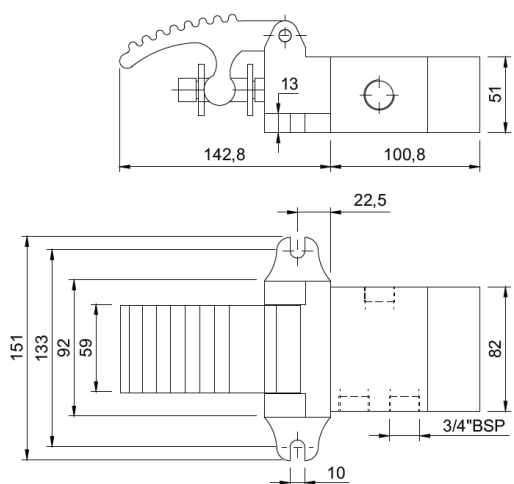

Pedal Diferencial 5 Vias

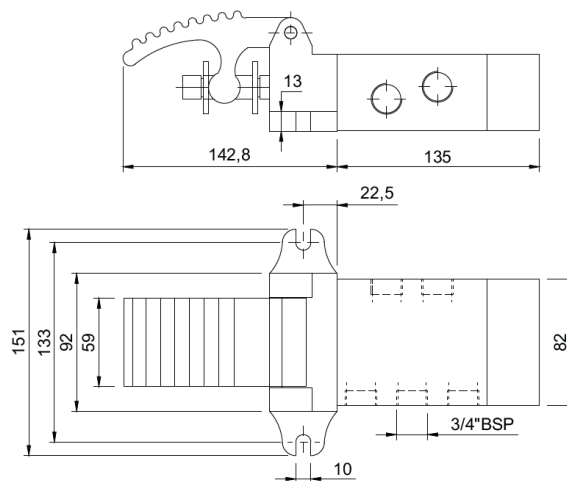

Duplo Piloto 3 Vias - 3 posições

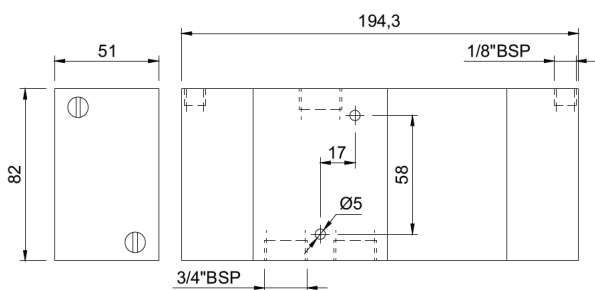

Duplo Piloto 5 Vias - 3 posições

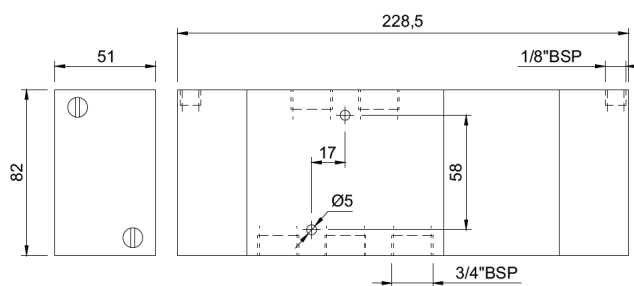

Solenóide Piloto 3 Vias - 3 posições

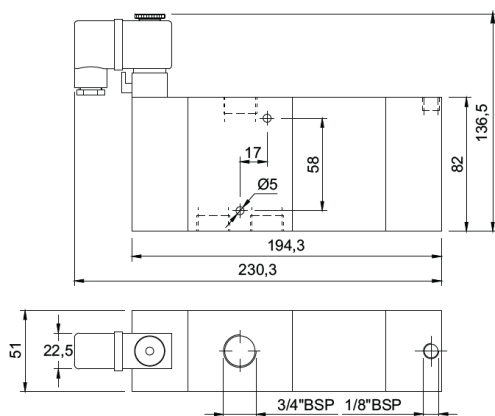

Solenóide Piloto 5 Vias - 3 posições

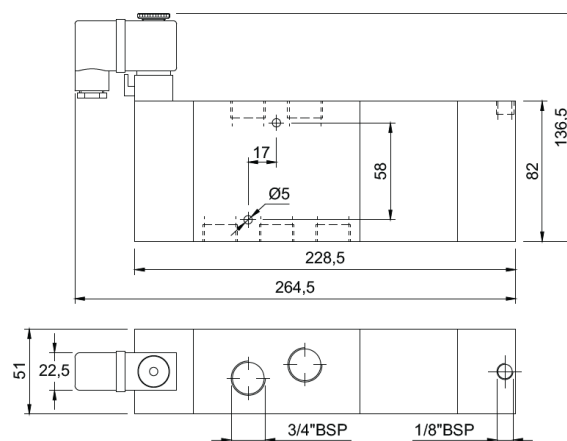

Duplo Solenoide 3 Vias - 3 posições

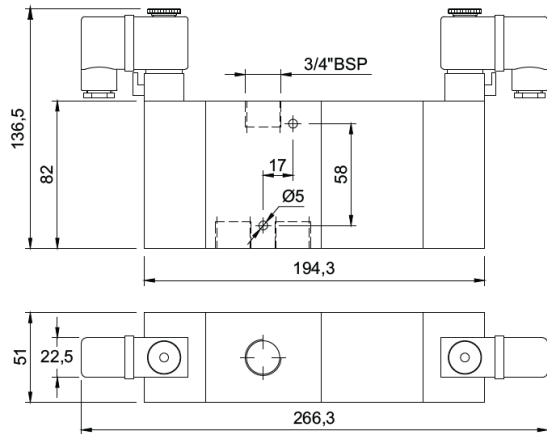

Duplo Solenoide 5 Vias - 3 posições

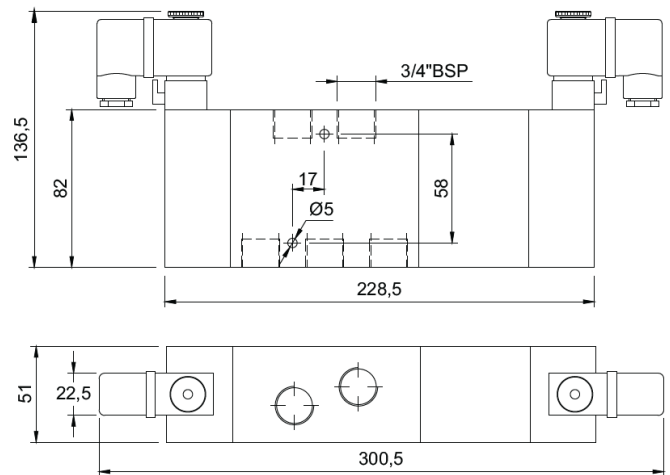

Pedal Piloto 3 Vias - 3 posições

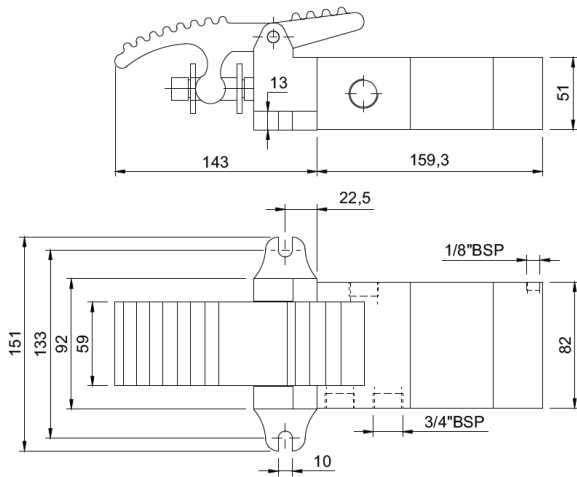

Pedal Piloto 5 Vias - 3 posições

